

# MiniLift160EE/MiniLift160EM

SystemRoMedic™

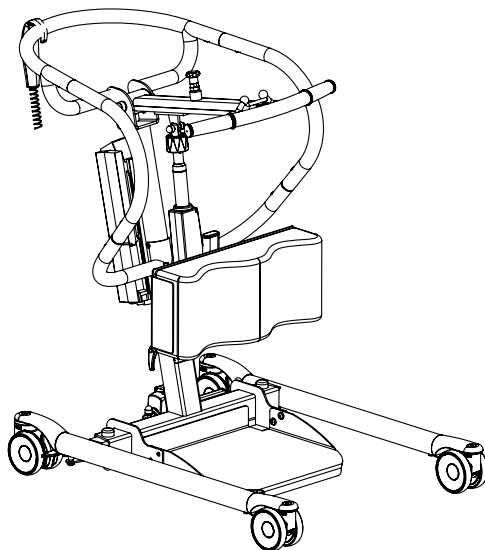

REF

60300010

60300011

60300012

60300013



**SWL: 160 kg/350 lbs**

# MiniLift160EE/MiniLift160EM

SystemRoMedic™

English

English

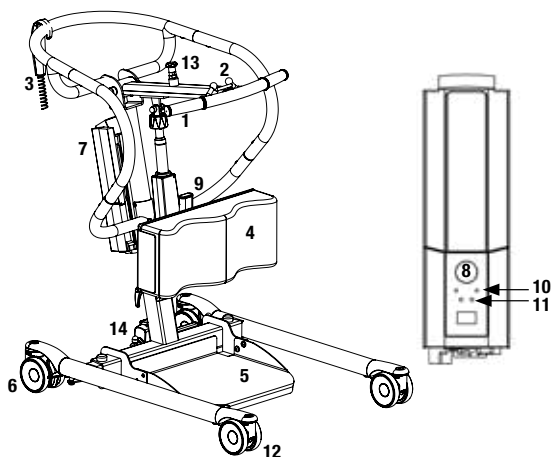

1. Lift arm
2. Hooks for lift vest/sling
3. Hand control
4. Leg support
5. Footplate
6. Rear castors with brakes
7. Battery
8. Emergency stop
9. Adjustment of leg support
10. Electrical emergency lowering
11. Charging lamp
12. Front castors
13. Locking mechanism for adjustment of lift arm
14. Base-width adjustment

MiniLift160 is a mobile sit-to-stand lift which has been developed to, as gently as possible, assist the user when rising from a sitting to a standing position. When MiniLift160 is combined with the appropriate lifting accessories, the user gets support under the feet, for the front of the lower legs and behind the back, which provides for a safe and secure sit-to-stand procedure. The construction safely moves the user forwards and upwards in a natural movement pattern and, at the same time, the leg muscles and balance is exercised. MiniLift160 is available in four variants with electrical (EE) or manual (EM) base widening and with standard height or low legs for use with lower beds. All variants are manufactured in steel for stability and strength and are suitable for users weighing up to 160 kg/350 lbs.



## Safety information

### Visual inspection

Inspect lift functions regularly. Check to ensure that material is free from damage.

### Before use

- Make certain the lift is properly assembled.
- Check sling bar connection and safety latch function.
- Check lifting function and base-width adjustment.
- Check to ensure that the actuator is correctly installed.



## Always read the user manual

- Always read the user manuals for all assistive devices used during a transfer.
- Keep the user manual where it is accessible to users of the product.
- Always make sure that you have the right version of the user manual.

Under no circumstances may the lift be used by persons who have not received instruction in the operation of the lift. It is strongly prohibited to modify the original product.

# Assembly

## Check to ensure that all components are included:

Lift unit, control box and battery pack, undercarriage, footplate, leg support, hand control and cord, user manual and charger.

## The lift is collapsed when delivered. Set up the lift, according to the following instructions

### (no tools required):

1. Lock castor brakes.
2. Place the mast in the base
3. Mount the locking handles at the base of the mast.
4. Tighten locking handle (1).
5. Check all mounting fixtures and locking handles.
6. Deactivate the emergency stop function and perform a final inspection (see Final inspection).

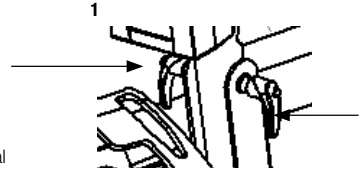

Connect cables: Hand control cord in HS, cable to lift unit on mast in outlet M1, and cable to base-width motor in outlet M2. (EE)

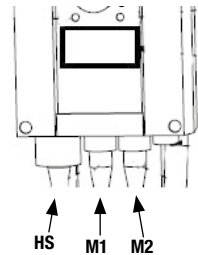

## To collapse the lift, follow the instructions below.

1. Lock castor brakes.
2. Change the base width pedal to horizontal.
3. Remove legsupport and footplate.
4. Run the lift arm to the lowest position, and then activate in the emergency stop button.
5. Push the lift arm in as far as possible.
6. Loosen the locking handle at the base of the mast (1). You need not remove the locking handle.
7. Lift up on the mast and lower it towards the undercarriage.



**Warning**, risk of pinching (between base and mast)

8. Pull the mast back and tighten the locking handle (1).

## Final inspection

Inspect the lift for signs of wear and damage. Check all castors and castor brakes.

Check all connections and fixtures including screws and bolts. Check the packaging to ensure that there are no loose parts.

Check the emergency stop function by activating the emergency stop button, and then pressing either the up or down button. If nothing happens when the up or down buttons are pressed, the emergency stop is functioning properly.

Grasp the hand control, press the up button and run the lift arm all the way up. Then, press the down button and run the liftarm all the way down.

Test base-width adjustment function by pushing down on the respective pedals for widening and narrowing the base. For EE use the buttons on the hand control.

Test lift function by lifting a person (not a user) using an approved sling. At the same time, check the emergency lowering function with someone in the lift, see section on Emergency lowering.

If the lift is functioning correctly, connect the charger and check to ensure that the charging lamp on the control box lights up.

### NOTE!

Before the lift is used for the first time:

- it must be charged for at least 4 hours. See section on charging batteries.
- the control box service counter needs to be reset. To reset the service counters press both lift buttons on the hand control at the same time for 5 seconds. An audio signal will indicate that the timer has been reset.

Keep the user manual where it is accessible to users of the product.

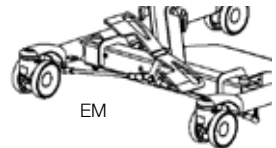
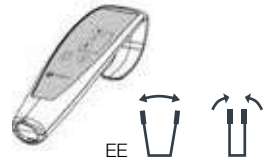
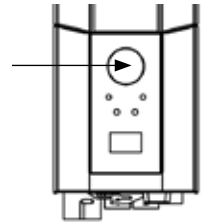
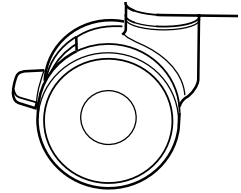



# Using the product



## Important Information

---

- The lift must be assembled according to the assembly instructions provided with the lift.
- The lift may only be used indoors and on a level floor.
- Lifting accessories must be properly fitted and tested in relation to the user's needs and functional ability.
- Do not leave the user unattended during a transfer situation. 
- Under no circumstances may max. load be exceeded. See section on Safe working load.
- The lift arm must be loaded throughout the entire lowering procedure to ensure a soft and smooth experience.
- Ensure that the user's feet do not get caught between the footplate and the floor. Ensure that the user's feet do not get caught between the footplate and the base when adjusting the base width.
- MiniLift160 is not intended for transporting users. It may only be used for short transfers.
- Never move the lift by pulling on the actuator! 
- The lift must not be used or immersed in or under water including showering.
- The lift should not be left / stored in a high humidity environment.
- The lift must not be charged in a wet room.
- To ensure optimal function, the lift must be inspected regularly. See section on Maintenance.
- Warranty applies only if repairs or alterations are done by an authorized technician.
- Using lifting accessories other than those approved by Handicare can entail a risk.
- Note the risk of pinching between base and mast when collapsing the lift. 

**To transfer with MiniLift160, the user must be able to:**

- support weight while standing
- understand instructions

## Safe working load

Different products on the same lift system (lift unit, sling bar, sling, scales and other lifting accessories) may have different allowable safe working loads. The lowest allowable safe working load always determines the safe working load of the assembled system. Always check the safe working loads for the lift and accessories before use. Contact your dealer if you have any questions.

## The control box and battery have the following features

1. **Emergency stop**
2. **Charging lamps**
3. **Display showing battery charge level**
4. **Connection for charger cable**
5. **Connection for base-width adjustment motor**
6. **Connection for lift arm actuator**
7. **Connection for hand control**
8. **Electrical emergency lowering**
9. **Handle for lifting battery**

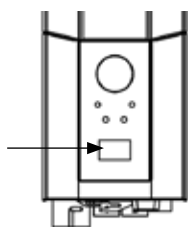
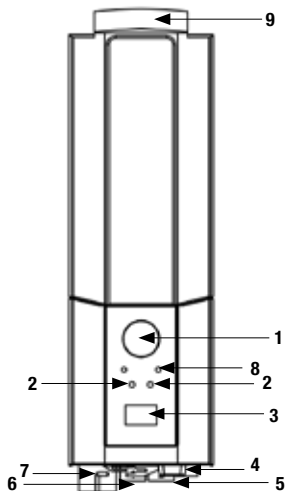

### Charging batteries

A tone sounding when using the lift indicates that the battery need recharging.  
 Charge the lift after use to ensure that the battery is always fully charged.  
 Lock the castor wheels when charging the battery.

1. Connect the charging cable to a power outlet and in the connection for charger cable. The symbol for charging is shown on the display.
2. Check to ensure that the lamps on the control box light up. The green LED lamp indicates that the charger is receiving power and the yellow LED lamp indicates that the battery is charging.
3. Charging stops automatically when the battery is fully charged.

Wall-mounted charger.

1. Remove the battery pack from the lift and place it in the wall-mounted charger.
2. Check to ensure that the LED lamp on the front of the charger lights up.

#### **NOTE!**

Before the lift is used for the first time, it must be charged for at least 4 hours.  
 For maximum battery life, charge batteries regularly. We recommend daily charging when the lift is used daily.

The emergency stop must be deactivated during charging.



### Battery information on the display

The battery discharging will be shown in four stages:

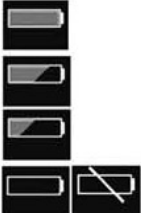

**Battery state 1:** The battery is ok, no need for charging (100 - 50 %).

**Battery state 2:** Battery needs charging. (50 - 25 %)

**Battery state 3:** Battery needs charging. (Less than 25 %) A tone sounds when a button is pressed in this battery state.

**Battery state 4:** The battery needs charging (17V or lower). At this stage some of the functionality of the lift is lost. At this battery stage it is only possible to drive the lifting arm down. Furthermore an audio signal will sound when a control button is activated. The symbol will switch between the two pictures for 10 seconds.

The battery symbol is shown when the box is active until power down (2 minutes after use). It is not possible to use other battery types than BAJ1/BAJ2.

The battery level is measured via voltage level. This means that it is possible to experience e.g. that the battery switches from state 1 to state 2 and back to state 1.

### Service information read-out

Basic service information can be read out on the display. To get the service information on the display please press the lifting arm up button for half a second. The information will be shown for ½ minute or until other buttons are activated.



- Total cycles done by the actuator
- Total work done by the actuator (ampere usage times seconds in use)
- Total number of overloads
- Days since last service/Days between services

## Hand control

### Raising/lowering the lift arm

Symbol indicate direction of travel.

Motion stops as soon as the button is released.

### Electrical base-width adjustment (EE)

Markings on the buttons of the hand control indicate function.

Motion stops as soon as the buttons are released.

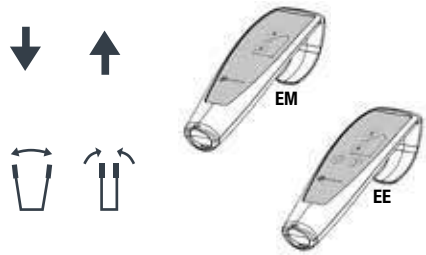

## Manual base-width adjustment (EM)

Push down on the respective pedals at the back of the lift to widen and narrow the base.

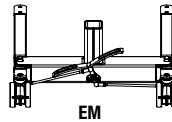

## Emergency stop

### To activate emergency stop

Activate the red emergency stop button on the control box.

### Resetting

Turn the button in the direction of the arrows until the button pops out.

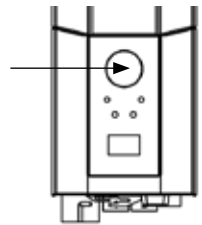

## Emergency lowering

### Manual emergency lowering

For manual emergency lowering, turn the round plastic knob on the actuator clockwise.

Manual emergency lowering

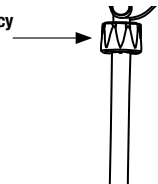

### Electrical emergency lowering

For electrical emergency lowering, use the down button on the control box. Use a narrow object such as a pen.

Electrical emergency lowering

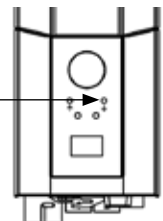



## Instructions for use

These instructions must be followed for correct use of MiniLift160.

### Caution

The actuator does not lower the lift arm when the lift is being lowered. This reduces the risk of the user being pinched by the lift arm. To prevent the lift arm from at first catching, and then suddenly fall the lift arm must be loaded throughout the entire lowering procedure, so that it is always supported by the actuator.

### Hand control functions

The hand control has four functions: up and down (lift arm), out and in (base width).  
Two functions cannot be used at the same time.

**NOTE:** The hand control functions do not operate if the emergency stop button is activated

**NOTE:** MiniLift160 is not intended for transporting users. It may only be used for short transfers.

**Caution** Never move the lift by pulling on the actuator.

**Caution** Ensure that the user's feet do not get caught between the footplate and the floor. Ensure that the user's feet do not get caught between the footplate and the base when adjusting the base width.

## Using MiniLift160

Place an appropriately sized ThoraxSling behind and below the user's hips, (see user manual for ThoraxSling). (1)

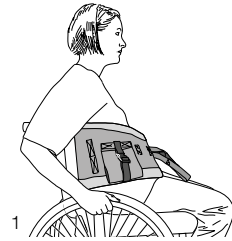

When the user has placed his/her feet on the footplate, move the lift forward towards the user. Place the lift as close as possible to the user. Take care to ensure that the user's shins are resting securely against the leg support, and then adjust (2) the leg support so that it does not press against the user's kneecaps (about 2 cm lower). (3)

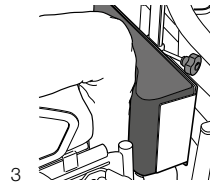
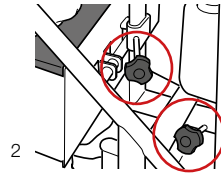

Raise the locking handle (4) on the lift arm and pull the lift arm out as far as possible towards the user.

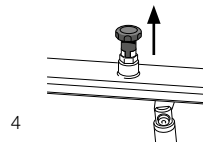

Select the sling loop that reaches the hook on the boom (shortest loop alternative). Hook the lift loops to the underside of the sling bar. (5)

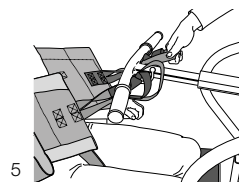

Raise the locking handle and draw the boom back, so that the lift straps on the sling are stretched, and then lower the locking handle back into position. (6)

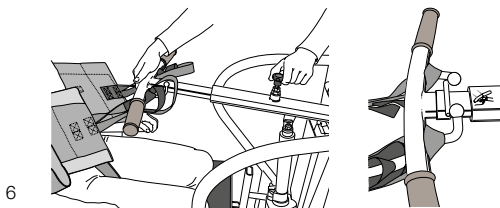

Instruct the user to lean back and allow himself/herself to be supported behind the back during raising. Raise the lift to the desired height and ensure that the user is standing with both feet on the footplate and is grasping the sling bar handles with both hands to avoid being pinched between the slingbar and lift loops. (7)

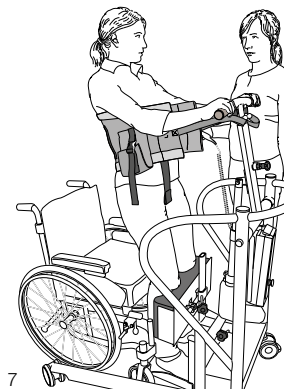

**Helpful hint:**

Use a longer loop alternative for short users and for users that cannot be fully raised.

Use a shorter loop alternative for taller users, and pull the lift arm out to allow the user to rise to a standing position.

## Trouble-shooting

### If the lift adjustment cannot be activated, check the following:

- That the emergency stop button is not activated.
- That all cables are properly and securely connected. Pull out the contact and plug it in again firmly.
- That battery charging is not in progress.
- That the battery is charged.

If the lift is not working properly, contact your dealer.

### If the lift makes unusual noises:

- Try to determine the source of the sound. Take the lift out of operation and contact your dealer.

## Accessories

ThoraxSling, polyester, XS-XXL, article no.: 45500003-009

ThoraxSling, wipeable, S-XXL, article no.: 45500004-009



ThoraxSling, with seat support, polyester, S-XL, article no.: 45600004-008



ThoraxSling, with seat support, disposable, non-woven, S-XL, article no.: 45690004-008



CalfStrap, article no.: 70200033



SlingBarWrap MiniLift, wipeable, article no.: 70200012



### Hand control

Hand control HB33-6, 6 buttons, with service, battery status and overload indicators, article no.: 70200089



# Maintenance

The lift must undergo thorough inspection at least once per year. Inspection must be performed by authorized personnel and in accordance with Handicare's service manual.

Repairs and maintenance may only be done by authorized personnel using original spare parts.



Used batteries are to be left at the nearest recycling station. Used batteries can also be returned to Handicare or a Handicare dealer for recycling.

## Cleaning/disinfection

If necessary, clean the lift with warm water or a soap solution and check that the castors are free from dirt and hair. Do not use cleaning agents containing phenol or chlorine, as this could damage the aluminium and the plastic materials. If disinfection is needed, 70 % ethanol, 45 % isopropanol or similar should be used.

## Storage and transportation



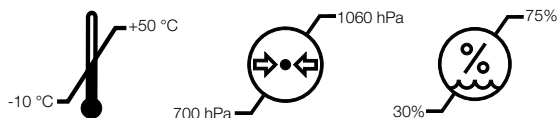



If the lift is not to be used for some time or e.g., during transport, we recommend that the emergency stop button be pressed in. The lift should be transported and stored in  $-10^{\circ}\text{C}$  to  $+50^{\circ}\text{C}$  and in normal humidity, 30% -75%. The air pressure should be between 700 and 1060 hPa. Let the lift reach room temperature before the batteries are charged or the lift is used.



## Service agreements

Handicare offers the possibility of service agreements for maintenance and regular testing of your mobile lift. Contact your local Handicare representative.

## Symbols

	Read user manual
	May not be discarded in domestic waste
	The product fulfills the demands stated in the MDD 93/42/EEC
	Type B, according to the degree of protection against electric shock.
	The device is intended for indoor use.
	Class II equipment
	Always Read The User Manual

## EMC

This equipment/system is intended for use by healthcare professionals only. This equipment/system may cause radio interference or may disrupt the operation of nearby equipment. It may be necessary to take mitigation measures, such as reorienting or relocating the equipment/system or shielding the location.

## Technical Information

<b>Lifting speed:</b>	1.4" /s, 35 mm/s without load.
<b>Batteries:</b>	Two 12V, 2.9 Ah valve-regulated, sealed, lead accumulator (gel-type batteries)
<b>Charger:</b>	400 mA
<b>Motor:</b>	DC 24V, 5,5 Amp. IP X4. Operationtime: 10% at maximum continuous operation of 2 minutes, maximum 5 cycles per minute. Push: 4 000N.
<b>Sound level:</b>	With load: upwards: 74.7 dB(A) downwards: 52.6 dB(A).
<b>Material</b>	Steel
<b>Emergency lowering:</b>	Mechanical and electrical
<b>Castors:</b>	Front 3.9", 100 mm, back 3.9", 100mm
<b>Weight:</b>	89.3 lbs, 40,5 kg
<b>Turning diameter:</b>	43,6", 1109 mm
<b>IP class:</b>	IP X4
<b>Expected lifetime:</b>	10 years
<b>Operating forces buttons on hand control:</b>	4 N
<b>Max. load:</b>	160kg/350 lbs

Medical Device Class I. The product complies with the requirements of the Medical Devices Directive 93/42/EEC.